

## 钨钢立铣刀



材质 F350 加工硬度HRC50 以下

材质 F450 加工硬度HRC55 以下

材质 F550 加工硬度HRC65 以下

尺寸				单价 (人民币)
刃径	刃长	柄径	全长	
1.0	2.0	3	50	30
1.0	2.0	4	50	30
1.5	3.5	3	50	30
1.5	3.5	4	50	30
2.0	6.0	3	50	30
2.0	6.0	4	50	30
2.5	6.0	3	50	30
2.5	6.0	4	50	30
3.0	8.0	3	50	30
3.0	8.0	4	50	30
3.5	10.0	4	50	30
4.0	10.0	4	50	30
5.0	13.0	5	50	52
5.0	13.0	6	50	52
6.0	15.0	6	50	52
8.0	20.0	8	60	92
10.0	25.0	10	75	146
12.0	30.0	12	75	196
16.0	40.0	16	100	494
18.0	40.0	20	100	704
20.0	40.0	20	100	704

尺寸				单价 (人民币)
刃径	刃长	柄径	全长	
1.0	2.0	4	50	42
1.5	3.5	4	50	42
2.0	6.0	4	50	42
2.5	6.0	4	50	42
3.0	8.0	4	50	42
3.5	10.0	4	50	42
4.0	10.0	4	50	42
5.0	13.0	6	50	62
6.0	15.0	6	50	62
8.0	20.0	8	60	110
10.0	25.0	10	75	176
12.0	30.0	12	75	250
16.0	40.0	16	100	592
18.0	40.0	20	100	854
20.0	40.0	20	100	854

尺寸				单价 (人民币)
刃径	刃长	柄径	全长	
1.0	2.0	4	50	84
1.5	3.5	4	50	84
2.0	6.0	4	50	84
2.5	6.0	4	50	84
3.0	8.0	4	50	84
3.5	10.0	4	50	84
4.0	10.0	4	50	84
5.0	13.0	6	50	120
6.0	15.0	6	50	120
8.0	20.0	8	60	234
10.0	25.0	10	75	338
12.0	30.0	12	75	480
16.0	40.0	16	100	1084
18.0	40.0	20	100	1508
20.0	40.0	20	100	1508

## 钨钢加长立铣刀



材质 F350 加工硬度HRC50 以下

材质 F450 加工硬度HRC55 以下

材质 F550 加工硬度HRC65 以下

尺寸				单价 (人民币)
刃径	刃长	柄径	全长	
3.0	12.0	6	100	108
4.0	16.0	6	100	108
5.0	20.0	6	100	108
6.0	30.0	6	100	108
8.0	35.0	8	100	164
10.0	40.0	10	100	224
12.0	45.0	12	100	295
16.0	75.0	16	150	
	80.0	16	200	
20.0	80.0	20	150	
	100.0	20	200	

尺寸				单价 (人民币)
刃径	刃长	柄径	全长	
3.0	12.0	6	100	116
4.0	16.0	6	100	116
5.0	20.0	6	100	116
6.0	30.0	6	100	116
8.0	35.0	8	100	174
10.0	40.0	10	100	250
12.0	45.0	12	100	330
16.0	75.0	16	150	1016
	80.0	16	200	1360
20.0	80.0	20	150	1430
	100.0	20	200	1990

尺寸				单价 (人民币)
刃径	刃长	柄径	全长	
3.0	16.0	6	100	174
4.0	20.0	6	100	174
5.0	25.0	6	100	174
6.0	25.0	6	100	174
8.0	32.0	8	100	320
10.0	40.0	10	100	458
12.0	45.0	12	100	596
16.0	75.0	16	150	1776
	80.0	16	200	1896
20.0	80.0	20	150	2370
	100.0	20	200	2842

## 钨钢球头铣刀



材质 F350 加工硬度HRC50 以下

材质 F450 加工硬度HRC55 以下

材质 F550 加工硬度HRC65 以下

尺寸				单价 (人民币)
刃径	刃长	柄径	全长	
R0.5	2.0	4	50	34
R0.75	3.5	4	50	34
R1	4.0	3	50	34
R1	4.0	4	50	34
R1.5	6.0	3	50	34
R1.5	6.0	4	50	34
R2	8.0	4	50	34
R2.5	10.0	5	50	56
R2.5	10.0	6	50	56
R3	12.0	6	50	56
R4	16.0	8	50	100
R5	20.0	10	75	156
R6	25.0	12	75	208
R8	32.0	16	100	510
R10	40.0	20	100	736

尺寸				单价 (人民币)
刃径	刃长	柄径	全长	
R0.5	2.0	4	50	48
R0.75	3.5	4	50	48
R1	4.0	4	50	48
R1.5	6.0	4	50	48
R2	8.0	4	50	48
R2.5	10.0	6	50	70
R3	12.0	6	50	70
R4	16.0	8	50	124
R5	20.0	10	75	190
R6	25.0	12	75	266
R8	32.0	16	100	660
R10	40.0	20	100	936

尺寸				单价 (人民币)
刃径	刃长	柄径	全长	
R0.5	2.0	4	50	94
R0.75	3.5	4	50	94
R1	4.0	4	50	94
R1.5	6.0	4	50	94
R2	8.0	4	50	94
R2.5	10.0	6	50	128
R3	12.0	6	50	128
R4	16.0	8	50	246
R5	20.0	10	75	352
R6	25.0	12	75	510
R8	32.0	16	100	1170
R10	40.0	20	100	1592

## 钨钢加长球铣刀



材质 F350 加工硬度HRC50 以下

材质 F450 加工硬度HRC55 以下

材质 F550 加工硬度HRC65 以下

尺寸				单价 (人民币)
刃径	刃长	柄径	全长	
R1	4.0	6	100	124
R1.5	6.0	6	100	124
R2	8.0	6	100	124
R2.5	10.0	6	100	124
R3	12.0	6	100	124
R4	16.0	8	100	178
R5	20.0	10	100	240
R6	25.0	12	100	304
R8	32.0	16	150	
	32.0	16	200	
R10	40.0	20	150	

尺寸				单价 (人民币)
刃径	刃长	柄径	全长	
R1	4.0	6	100	128
R1.5	6.0	6	100	128
R2	8.0	6	100	128
R2.5	10.0	6	100	128
R3	12.0	6	100	128
R4	16.0	8	100	180
R5	20.0	10	100	270
R6	25.0	12	100	358
R8	32.0	16	150	1126
	32.0	16	200	1370
R10	40.0	20	150	1560

尺寸				单价 (人民币)
刃径	刃长	柄径	全长	
R1	4.0	6	100	194
R1.5	6.0	6	100	194
R2	8.0	6	100	194
R2.5	10.0	6	100	194
R3	12.0	6	100	194
R4	16.0	8	100	322
R5	20.0	10	100	476
R6	25.0	12	100	610
R8	32.0	16	150	1786
	32.0	16	200	1916
R10	40.0	20	150	2410

# 钨钢铣刀 | Carbide End Milling

## 钨钢圆鼻刀

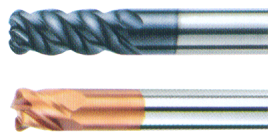

材质 FR450 加工硬度HRC50 °以下						
尺寸						单价 (人民币)
刃径	角R	刃长	柄径	全长		
2	R0.5	5.0	4	50	64	
3	R0.2	6.0	4	50	64	
3	R0.5	6.0	4	50	64	
4	R0.2	8.0	4	50	64	
4	R0.3	8.0	4	50	64	
4	R0.5	8.0	4	50	64	
4	R1.0	8.0	4	50	64	
4	R0.5	25.0	4	75	90	
4	R1.0	25.0	4	75	90	
5	R0.5	10.0	6	50	84	
5	R1.0	10.0	6	50	84	
5	R1.5	10.0	6	50	84	
6	R0.5	12.0	6	50	84	
6	R1.0	12.0	6	50	84	
6	R1.5	12.0	6	50	84	
6	R0.5	25.0	6	75	156	
6	R1.0	25.0	6	100	156	
8	R0.5	16.0	8	60	160	
8	R1.0	16.0	8	60	160	
8	R1.5	16.0	8	60	160	
8	R2.0	16.0	8	60	160	
8	R0.5	30.0	8	100	232	
8	R1.0	30.0	8	100	232	
10	R0.5	20.0	10	75	246	
10	R1.0	20.0	10	75	246	
10	R1.5	20.0	10	75	246	
10	R2.0	20.0	10	75	246	
10	R0.5	35.0	10	100	346	
10	R1.0	35.0	10	100	346	
12	R0.5	25.0	12	75	334	
12	R1.0	25.0	12	75	334	
12	R1.5	25.0	12	75	334	
12	R2.0	25.0	12	75	334	
12	R0.5	40.0	12	100	466	
12	R1.0	40.0	12	100	466	
16	R1.0	45.0	16	150	1060	
16	R2.0	45.0	16	150	1060	



## 二刃钨钢铝用刀

材质 FA350 通用型					
尺寸					单价 (人民币)
刃径	刃长	柄径	全长		
1.0	3.0	4	50	48	
1.5	4.0	4	50	48	
2.0	5.0	4	50	48	
2.5	7.0	4	50	48	
3.0	8.0	4	50	48	
3.0	12.0	6	60	140	
4.0	10.0	4	50	76	
4.0	16.0	6	60	140	
5.0	15.0	6	50	76	
5.0	20.0	6	60	160	
6.0	20.0	6	50	76	
6.0	25.0	6	75	160	
8.0	25.0	8	60	132	
8.0	32.0	8	75	250	
10.0	30.0	10	75	220	
10.0	45.0	10	100	290	
12.0	35.0	12	75	316	
12.0	45.0	12	100	400	
16.0	45.0	16	100	732	
16.0	65.0	16	150	950	
20.0	50.0	20	100	1084	
20.0	75.0	20	150	1390	



## 三刃钨钢铝用刀

材质 FA350 通用型					
尺寸					单价 (人民币)
刃径	刃长	柄径	全长		
1.0	3.0	4	50	48	
1.5	4.0	4	50	48	
2.0	5.0	4	50	48	
2.5	7.0	4	50	48	
3.0	8.0	4	50	48	
4.0	10.0	4	50	76	
5.0	15.0	6	50	76	
6.0	20.0	6	50	76	
8.0	25.0	8	60	132	
10.0	30.0	10	75	220	
12.0	35.0	12	75	316	
16.0	45.0	16	100	732	
20.0	50.0	20	100	1084	



## 二刃钨钢球型铝用刀

材质 FA350 通用型					
尺寸					单价 (人民币)
刃径	刃长	柄径	全长		
R1.0	14	6	60	58	
R1.5	6	6	60	58	
R2.0	8	6	60	58	
R2.5	10	6	60	86	
R3.0	12	6	60	86	
R4.0	16	8	75	152	
R5.0	20	10	75	260	
R6.0	24	12	75	356	

## 钨钢锥度铣刀

材质 FR450 加工硬度HRC55 °以下						
锥度	尺寸				单价 (人民币)	
	刃径	刃长	柄径	全长		
1/2 °	1	4	4	50	192	
	1.5	5	4	50	192	
	2	6	4	50	192	
	2.5	8	4	50	192	
	3	10	6	50	192	
	4	15	6	50	205	
	5	20	6	50	239	
	6	20	6	60	299	
	8	25	8	75	446	
	10	35	10	100	632	
1 °	1	4	4	50	192	
	1.5	5	4	50	192	
	2	6	4	50	192	
	2.5	8	4	50	192	
	3	10	6	50	192	
	4	15	6	50	205	
	5	20	6	50	239	
	6	20	6	60	299	
	8	25	8	75	446	
	10	35	10	100	632	
1-1/2 °	1	4	4	50	192	
	1.5	5	4	50	192	
	2	6	4	50	192	
	2.5	8	4	50	192	
	3	10	6	50	192	
	4	15	6	50	205	
	5	20	6	60	239	
	6	20	6	60	299	
	8	25	8	75	446	
	10	35	10	100	679	
2 °	1	4	4	50	192	
	1.5	5	4	50	192	
	2	6	4	50	192	
	2.5	8	4	50	192	
	3	10	6	50	192	
	4	15	6	50	205	
	5	20	6	60	287	
	6	20	6	60	299	
	8	25	8	75	495	
	10	35	12	100	781	
2-1/2 °	1	4	4	50	192	
	1.5	5	4	50	192	
	2	6	4	50	192	
	2.5	8	4	50	192	
	3	10	6	50	192	
	4	15	6	50	205	
	5	20	6	60	287	
	6	20	6	60	367	
	8	25	10	75	632	
	10	35	12	100	829	
3 °	1	4	4	50	192	
	1.5	5	4	50	192	
	2	6	4	50	192	
	2.5	8	4	50	192	
	3	10	6	50	192	
	4	15	6	60	205	
	5	20	6	60	287	
	6	20	8	60	367	
	8	25	10	75	632	
	10	35	12	100	906	
5 °	1	4	4	50	255	
	1.5	5	4	50	255	
	2	6	4	50	225	
	2.5	8	6	50	225	
	3	10	6	50	306	
	4	15	6	75	365	
	5	20	8	75	367	
	6	20	8	75	460	
	8	25	12	100	752	
	10	35	16	100	1110	

**NEW**  
强力推荐



## 钨钢不锈钢用刀

材质 FA600M					
尺寸					单价 (人民币)
刃径	刃长	柄径	全长		
3.0	8.0	4	50	120	
4.0	10.0	4	50	120	
5.0	15.0	4	50	140	
6.0	20.0	6	50	140	
8.0	25.0	8	60	250	
10.0	30.0	10	75	390	
12.0	35.0	12	75	512	

铣刀  
锯片  
成型刀

钨钢  
铣刀

非标  
成型刀

高速  
钢铣刀

焊刀  
式铣刀

钨钢  
圆棒

## 微小径钨钢立铣刀



材质 F350 加工硬度HRC45 °以下					材质 F450 加工硬度HRC55 °以下					材质 F550 加工硬度HRC65 °以下				
尺寸				单价 (人民币)	尺寸				单价 (人民币)	尺寸				单价 (人民币)
刃径	刃长	柄径	全长		刃径	刃长	柄径	全长		刃径	刃长	柄径	全长	
0.2	0.4	4	50	95	0.2	0.4	4	50	120	0.2	0.4	4	50	170
0.3	0.6	4	50	85	0.3	0.6	4	50	100	0.3	0.6	4	50	170
0.4	0.8	4	50	85	0.4	0.8	4	50	100	0.4	0.8	4	50	170
0.5	1.0	4	50	75	0.5	1.0	4	50	95	0.5	1.0	4	50	150
0.6	1.2	4	50	80	0.6	1.2	4	50	95	0.6	1.2	4	50	150
0.7	1.4	4	50	80	0.7	1.4	4	50	95	0.7	1.4	4	50	150
0.8	1.6	4	50	80	0.8	1.6	4	50	95	0.8	1.6	4	50	150
0.9	1.8	4	50	80	0.9	1.8	4	50	95	0.9	1.8	4	50	150
1.1	3.0	4	50	80	1.1	3.0	4	50	95	1.1	3.0	4	50	150
1.2	3.0	4	50	80	1.2	3.0	4	50	95	1.2	3.0	4	50	150
1.3	3.0	4	50	80	1.3	3.0	4	50	95	1.3	3.0	4	50	150
1.4	3.0	4	50	80	1.4	3.0	4	50	95	1.4	3.0	4	50	150
1.6	4.0	4	50	80	1.6	4.0	4	50	95	1.6	4.0	4	50	150
1.7	4.0	4	50	80	1.7	4.0	4	50	95	1.7	4.0	4	50	150
1.8	5.0	4	50	80	1.8	5.0	4	50	95	1.8	5.0	4	50	150
1.9	5.0	4	50	80	1.9	5.0	4	50	95	1.9	5.0	4	50	150

铣刀  
锯片  
成型刀

## 微小径圆头钨钢立铣刀



材质 F350 加工硬度HRC45 °以下					材质 F450 加工硬度HRC55 °以下					材质 F550 加工硬度HRC65 °以下				
尺寸				单价 (人民币)	尺寸				单价 (人民币)	尺寸				单价 (人民币)
刃径	刃长	柄径	全长		刃径	刃长	柄径	全长		刃径	刃长	柄径	全长	
R0.15	0.6	4	50	95	R0.15	0.6	4	50	155	R0.15	0.6	4	50	185
R0.2	0.8	4	50	95	R0.2	0.8	4	50	130	R0.2	0.8	4	50	185
R0.25	1.0	4	50	80	R0.25	1.0	4	50	120	R0.25	1.0	4	50	165
R0.3	1.2	4	50	85	R0.3	1.2	4	50	120	R0.3	1.2	4	50	165
R0.4	1.6	4	50	85	R0.4	1.6	4	50	105	R0.4	1.6	4	50	165
R0.6	2.4	4	50	85	R0.6	2.4	4	50	105	R0.6	2.4	4	50	165
R0.75	3.0	4	50	80	R0.75	3.0	4	50	95	R0.75	3.0	4	50	150
R0.8	3.2	4	50	85	R0.8	3.2	4	50	105	R0.8	3.2	4	50	165
R1.25	5.0	4	50	80	R1.25	5.0	4	50	95	R1.25	5.0	4	50	150

钨钢  
铣刀

非标  
成型刀

## 深沟专用钨钢立铣刀



材质 F450 加工硬度HRC55 °以下						
尺寸						单价 (人民币)
刃径	颈径	刃长	有效长	柄径	全长	
Ø0.5	0.45	0.7	4.0	4.0	50	
Ø0.5	0.45	0.7	6.0	4.0	50	
Ø0.5	0.45	0.7	8.0	4.0	50	
Ø1.0	0.95	1.5	4.0	4.0	50	
Ø1.0	0.95	1.5	6.0	4.0	50	
Ø1.0	0.95	1.5	8.0	4.0	50	
Ø1.0	0.95	1.5	10.0	4.0	50	
Ø1.0	0.95	1.5	12.0	4.0	50	
Ø1.0	0.95	1.5	14.0	4.0	50	
Ø1.5	1.45	2.3	6.0	4.0	50	
Ø1.5	1.45	2.3	8.0	4.0	50	
Ø1.5	1.45	2.3	10.0	4.0	50	
Ø1.5	1.45	2.3	12.0	4.0	50	
Ø2.0	1.95	3.0	6.0	4.0	50	
Ø2.0	1.95	3.0	8.0	4.0	50	
Ø2.0	1.95	3.0	10.0	4.0	50	
Ø2.0	1.95	3.0	12.0	4.0	50	
Ø2.0	1.95	3.0	14.0	4.0	50	
Ø2.0	1.95	3.0	16.0	4.0	50	
Ø2.5	2.40	3.7	8.0	4.0	50	
Ø2.5	2.40	3.7	10.0	4.0	50	
Ø2.5	2.40	3.7	12.0	4.0	50	
Ø2.5	2.40	3.7	14.0	4.0	50	
Ø2.5	2.40	3.7	16.0	4.0	50	
Ø2.5	2.40	3.7	18.0	4.0	50	
Ø2.5	2.40	3.7	20.0	4.0	50	
Ø3	2.85	4.5	6.0	6.0	50	
Ø3	2.85	4.5	8.0	6.0	50	
Ø3	2.85	4.5	10.0	6.0	50	
Ø3	2.85	4.5	12.0	6.0	50	
Ø3	2.85	4.5	14.0	6.0	50	
Ø3	2.85	4.5	16.0	6.0	50	
Ø3	2.85	4.5	18.0	6.0	50	
Ø3	2.85	4.5	20.0	6.0	50	
Ø4	3.85	6.0	12.0	6.0	60	
Ø4	3.85	6.0	16.0	6.0	60	
Ø4	3.85	6.0	20.0	6.0	60	
Ø4	3.85	6.0	25.0	6.0	60	
Ø5	4.85	7.5	16.0	6.0	60	
Ø5	4.85	7.5	25.0	6.0	70	

高速  
钢铣刀

焊刀  
式铣刀

钨钢  
圆棒

## 深沟专用钨钢球刀



材质 F450 加工硬度HRC55 °以下						
尺寸						单价 (人民币)
刃径	颈径	刃长	有效长	柄径	全长	
R0.25	0.45	0.7	4.0	4.0	50	
R0.25	0.45	0.7	6.0	4.0	50	
R0.50	0.95	1.5	4.0	4.0	50	
R0.50	0.95	1.5	6.0	4.0	50	
R0.50	0.95	1.5	8.0	4.0	50	
R0.50	0.95	1.5	10.0	4.0	50	
R0.50	0.95	1.5	12.0	4.0	50	
R0.75	1.45	2.3	8.0	4.0	50	
R0.75	1.45	2.3	12.0	4.0	50	
R0.75	1.45	2.3	16.0	4.0	50	
R1.00	1.95	3.0	6.0	4.0	50	
R1.00	1.95	3.0	8.0	4.0	50	
R1.00	1.95	3.0	10.0	4.0	50	
R1.00	1.95	3.0	12.0	4.0	50	
R1.00	1.95	3.0	16.0	4.0	50	
R1.00	1.95	3.0	20.0	4.0	50	
R1.25	2.40	3.7	8.0	4.0	50	
R1.25	2.40	3.7	12.0	4.0	50	
R1.25	2.40	3.7	16.0	4.0	60	
R1.25	2.40	3.7	20.0	4.0	60	
R1.50	2.85	4.5	8.0	4.0	50	
R1.50	2.85	4.5	10.0	4.0	50	
R1.50	2.85	4.5	12.0	4.0	50	
R1.50	2.85	4.5	16.0	4.0	50	
R1.50	2.85	4.5	20.0	4.0	50	
R2.00	3.85	6.0	10.0	6.0	60	
R2.00	3.85	6.0	16.0	6.0	60	
R2.00	3.85	6.0	20.0	6.0	60	
R2.50	4.85	6.0	16.0	6.0	60	
R2.50	4.85	6.0	25.0	6.0	60	

非标刀具订做  
最快一天交货

## 六刃钨钢立铣刀



材质 F450 加工硬度HRC55 °以下						
尺寸						单价 (人民币)
刃径	刃长	柄径	全长	刃径	刃长	
6.0	18	6	60	6.0	18	120
6.0	18	6	75	6.0	18	180
8.0	20	8	60	8.0	20	210
8.0	20	8	75	8.0	20	295
10.0	30	10	75	10.0	30	350
10.0	30	10	100	10.0	30	480
12.0	32	12	75	12.0	32	480
12.0	32	12	100	12.0	32	600
16.0	40	16	100	16.0	40	760
16.0	40	16	150	16.0	40	950
20.0	45	20	100	20.0	45	1100
20.0	45	20	150	20.0	45	1350

## 沉头六角铣刀

材质 HSS 全部 T N 镀钛规格							
尺寸							单价 (人民币)
刃径	引导径	刃外径	柄径	导刃长	刃长	全长	
M3	3.2	5.9	6	3	7	37	140
M4	4.2	7.4	6	4	10	44	153
M5	5.2	8.9	6	5	13	51	173
M6	6.2	10.4	8	6	15	58	193
M8	8.2	13.4	10	8	16	67	267
M10	10.3	16.8	12	10	16	74	347
M12	12.4	18.8	12	12	20	83	447
M14	14.4	24.0	12	14	20	90	560
M16	16.5	26.0	16	16	22	100	660
M18	18.5	28.0	16	18	24	104	767
M20	21	30.0	16	21	26	109	913
M 1/4	6.55	11	33	6	14	58	233
M 5/16	8.25	14	38	8	16	67	280
M 3/8	9.8	15	43	9	16	73	347
M 1/2	13.2	20	46	13	20	83	507

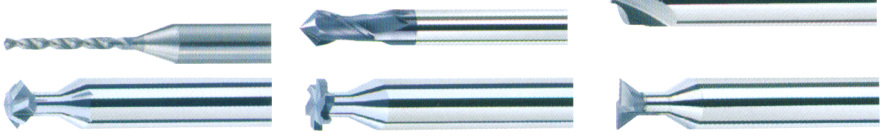

# 钨钢铣刀 | Carbide End Milling

## 钨钢T型铣刀

MICRO BAN ARB DE ISOT CUTTERS Key seat-Flat life

▪ CEK



- 1 径 ( ) 6mm, 榫为 榫设计, 5.0 0.9 2.5 4.0 50 6 4
- 2 径 3.0mm (含) 以上 [ 榫设计 ], 1 1.0mm, 榫 1.0mm 以上 [ 榫设计 ],

刃径 d	刃长 L1	头径 Nd	头长 NL	全长 L	柄径 D	刃数 F	白刀订购编号 Uncoated Order n°N	建议售价 Price ¥
4.0	0.5	2.5	3.5	50	4	4	CEK040005004	436
4.0	0.6	2.5	3.5	50	4	4	CEK040006004	436
4.0	0.7	2.5	3.5	50	4	4	CEK040007004	436
4.0	0.8	2.5	3.5	50	4	4	CEK040008004	436
4.0	0.9	2.5	3.5	50	4	4	CEK040009004	436
4.0	1.0	2.5	3.5	50	4	4	CEK040010004	436
4.0	1.5	2.5	3.5	50	4	4	CEK040015004	410
4.0	2.0	2.5	3.5	50	4	4	CEK040020004	410
5.0	0.5	2.5	4.0	50	6	4	CEK050005004	436
5.0	0.6	2.5	4.0	50	6	4	CEK050006004	436
5.0	0.7	2.5	4.0	50	6	4	CEK050007004	436
5.0	0.8	2.5	4.0	50	6	4	CEK050008004	436
5.0	0.9	2.5	4.0	50	6	4	CEK050009004	436
5.0	1.0	2.5	4.0	50	6	4	CEK050010004	436
5.0	1.5	2.5	4.0	50	6	4	CEK050015004	410
5.0	2.0	2.5	4.0	50	6	4	CEK050020004	410
6.0	0.5	2.0	4.0	50	6	6	CEK060005006	436
6.0	0.6	3.0	4.0	50	6	6	CEK060006006	436
6.0	0.7	3.0	4.0	50	6	6	CEK060007006	436
6.0	0.8	3.0	4.0	50	6	6	CEK060008006	436
6.0	0.9	3.0	4.0	50	6	6	CEK060009006	436
6.0	1.0	3.0	4.0	50	6	6	CEK060010006	436
6.0	1.5	3.0	4.0	50	6	6	CEK060015006	410
6.0	2.0	3.0	4.0	50	6	6	CEK060020006	410
8.0	1.0	4.0	4.0	60	8	6	CEK080010006	564
8.0	1.5	4.0	4.0	60	8	6	CEK080015006	590
8.0	2.0	4.0	4.0	60	8	6	CEK080020006	590
10.0	1.0	5.0	6.0	75	10	6	CEK100010006	641
10.0	1.5	5.0	6.0	75	10	6	CEK100015006	641
10.0	2.0	5.0	6.0	75	10	6	CEK100020006	621
12.0	1.0	6.0	7.0	75	12	6	CEK120010006	769
12.0	1.5	6.0	7.0	75	12	6	CEK120015006	769
12.0	2.0	6.0	7.0	75	12	6	CEK120020006	769

## 钨钢T型铣刀

MICRO BAN ARB DE ISOT CUTTERS Key seat-Flat life

▪ AEK

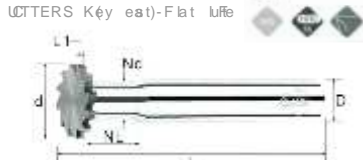

- 1 径 ( ) 6mm, 榫为 榫设计, 5.0 0.9 2.5 4.0 50 6 4
- 2 径 3.0mm (含) 以上 [ 榫设计 ], 1 1.0mm, 榫 1.0mm 以上 [ 榫设计 ],

刃径 d	刃长 L1	头径 Nd	头长 NL	全长 L	柄径 D	刃数 F	白刀订购编号 Uncoated Order n°N	建议售价 Price ¥
16.0	1.0	8.0	10.0	100	12	10	AEK160010010	769
16.0	1.5	8.0	10.0	100	12	10	AEK160015010	769
16.0	2.0	8.0	10.0	100	12	10	AEK160020010	769
16.0	2.5	8.0	10.0	100	12	10	AEK160025010	821
16.0	3.0	8.0	10.0	100	12	10	AEK160030010	821
20.0	0.5	10.0	14.0	100	12	12	AEK200005012	846
20.0	1.0	10.0	14.0	100	12	12	AEK200010012	846
20.0	1.5	10.0	14.0	100	12	12	AEK200015012	846
20.0	2.0	10.0	14.0	100	12	12	AEK200020012	846
20.0	2.5	10.0	14.0	100	12	12	AEK200025012	923
20.0	3.0	10.0	14.0	100	12	12	AEK200030012	923
25.0	1.0	12.0	16.0	100	16	16	AEK250010016	923
25.0	2.0	12.0	16.0	100	16	16	AEK250020016	923
25.0	2.5	12.0	16.0	100	16	16	AEK250025016	1000
25.0	3.0	12.0	16.0	100	16	16	AEK250030016	1000
25.0	4.0	12.0	16.0	100	16	16	AEK250040016	1026
25.0	5.0	12.0	16.0	100	16	16	AEK250050016	1077
30.0	1.0	15.0	18.0	100	16	16	AEK300010016	1026
30.0	2.0	15.0	18.0	100	16	16	AEK300020016	1026
30.0	3.0	15.0	18.0	100	16	16	AEK300030016	1077
30.0	4.0	15.0	18.0	100	16	16	AEK300040016	1128
30.0	5.0	15.0	18.0	100	16	16	AEK300050016	1179

## 钨钢外圆槽铣刀

MICRO BAN ARB DE CONVEX CUTTERS

▪ CEC



- 1 径 ( ) 6mm, 榫为 榫设计, 5.0 0.9 2.5 4.0 50 6 4
- 2 径 3.0mm (含) 以上 [ 榫设计 ], 1 1.0mm, 榫 1.0mm 以上 [ 榫设计 ],

刃径 d	R角 R	刃长 L1	头径 Nd	头长 NL	全长 L	柄径 D	刃数 F	白刀订购编号 Uncoated Order n°N	建议售价 Price ¥
4.0	0.3R	0.6	2.0	3.5	50	6	4	CEC040006004	513
4.0	0.5R	1.0	2.0	3.5	50	6	4	CEC040010004	487
4.0	1.0R	2.0	2.0	3.5	50	6	4	CEC040020004	487
5.0	0.3R	0.6	2.2	3.5	50	6	4	CEC050006004	513
5.0	0.5R	1.0	2.2	3.5	50	6	4	CEC050010004	487
5.0	1.0R	2.0	2.2	3.5	50	6	4	CEC050020004	487
6.0	0.3R	0.6	2.7	4.0	50	6	4	CEC060006004	513
6.0	0.5R	1.0	2.7	4.0	50	6	4	CEC060010004	487
6.0	1.0R	2.0	2.7	4.0	50	6	4	CEC060020004	487
8.0	0.3R	0.6	3.6	5.0	60	8	6	CEC080006006	667
8.0	0.5R	1.0	3.6	5.0	60	8	6	CEC080010006	667
8.0	1.0R	2.0	3.6	5.0	60	8	6	CEC080020006	667
10.0	0.3R	0.6	4.5	6.0	75	10	6	CEC100006006	769
10.0	0.5R	1.0	4.5	6.0	75	10	6	CEC100010006	769
10.0	1.0R	2.0	4.5	6.0	75	10	6	CEC100020006	769
10.0	1.5R	3.0	4.5	6.0	75	10	6	CEC100030006	769
10.0	2.0R	4.0	4.5	6.0	75	10	6	CEC100040006	769
12.0	0.3R	0.6	5.5	6.0	75	12	6	CEC120006006	923
12.0	0.5R	1.0	5.5	6.0	75	12	6	CEC120010006	923
12.0	1.0R	2.0	5.5	6.0	75	12	6	CEC120020006	923
12.0	1.5R	3.0	5.5	6.0	75	12	6	CEC120030006	923
12.0	2.0R	4.0	5.5	6.0	75	12	6	CEC120040006	923

## 钨钢等角鸠尾槽铣刀

MICRO BAN ARB DE WANGULAR CUTTERS (Dove tail)

▪ CECSW



刃径 d	角度	刃长 L1	头径 Nd	头长 NL	全长 L	柄径 D	刃数 F	白刀订购编号 Uncoated Order n°N	建议售价 Price ¥
6.0	60°	1.8	2.7	4	60	6	4	CECSW060018060	474
8.0	60°	2.4	3.6	5	60	8	6	CECSW080024060	615
10.0	60°	3.1	4.5	6	75	10	6	CECSW100031060	705
12.0	60°	3.7	5.4	7	75	12	6	CECSW120037060	821
6.0	90°	2.8	3.0	4	60	6	4	CECSW060028090	474
8.0	90°	3.8	4.0	5	60	8	6	CECSW080038090	615
10.0	90°	4.8	5.0	6	75	10	6	CECSW100048090	705
12.0	90°	5.8	6.0	7	75	12	6	CECSW120058090	821

## 钨钢倒角兼用铣刀 - 2刃

MICRO BAN ARB DE Apointed END MILL-2F

▪ CEC2



先端角	刃径 d	刃长 L1	全长 L	柄径 D	镀膜订购编号 Coated Order n°N	建议售价 Price ¥
90°	3.0	6.0	50	6	CEC2030090A	346
90°	4.0	8.0	50	6	CEC2040090A	346
90°	5.0	10.0	75	6	CEC2050090A	385
90°	6.0	12.0	75	6	CEC2060090A	385
90°	8.0	16.0	100	8	CEC2080090A	462
90°	10.0	20.0	100	10	CEC2100090A	692
90°	12.0	24.0	100	12	CEC2120090A	974
90°	16.0	32.0	100	16	CEC2160090A	1538
90°	20.0	40.0	100	20	CEC2200090A	2308
120°	3.0	6.0	50	6	CEC2030000A	346
120°	4.0	8.0	50	6	CEC2040000A	346
120°	5.0	10.0	75	6	CEC2050000A	385
120°	6.0	12.0	75	6	CEC2060000A	385
120°	8.0	16.0	100	8	CEC2080000A	462
120°	10.0	20.0	100	10	CEC2100000A	692
120°	12.0	24.0	100	12	CEC2120000A	974
120°	16.0	32.0	100	16	CEC2160000A	1538
120°	20.0	40.0	100	20	CEC2200000A	2308

## 钨钢内R角铣刀 - 2刃

MICRO BAN ARB DE INNER ADJUST CUTTER - F2

▪ CEIR2

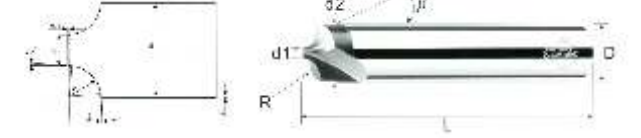

R角 R	柄斜角	先端径 d1	粗端径 d2	全长 L	柄径 D	白刀订购编号 Uncoated Order n°N	建议售价 Price ¥
0.5R	15°	1.5	2.7	50	4	CEIR20150050	333
0.75R	15°	1.5	3.2	50	4	CEIR20150075	333
1.0R	15°	1.5	3.7	50	4	CEIR20150100	333
1.25R	-	1.5	4.2	50	6	CEIR20150125	333
1.5R	15°	1.5	4.7	50	6	CEIR20150150	333
1.75R	15°	1.5	5.2	50	6	CEIR20150175	333
2.0R	15°	1.5	5.7	50	6	CEIR20150200	333
2.5R	-	1.5	6.7	50	8	CEIR20150250	462
3.0R	15°	1.5	7.7	50	8	CEIR20150300	462
4.0R	15°	2.0	10.2	60	12	CEIR20200400	897
5.0R	15°	3.0	13.2	75	16	CEIR20300500	1410
6.0R	15°	3.0	15.2	75	16	CEIR20300600	1410

## 钨钢扁形倒角铣刀 - 2刃

MICRO BAN ARB DE FLAT CHAMFERING END MILL-2R

▪ CEFC



钨钢冲头 - 六角型

CARBIDE UNCH-HEXAGON

CLPH

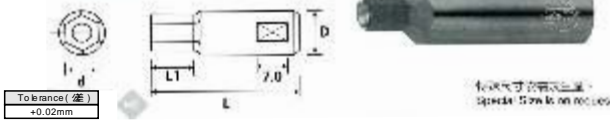

直径 d	刃长 L1	全长 L	柄径 D	订购编号 Order n	建议售价 Price ¥
1.5	2.5	28	8	CLPH01508	420
2.0	3.0	28	8	CLPH02008	420
2.5	4.0	28	8	CLPH02508	420
3.0	4.5	28	8	CLPH03008	420
4.0	6.0	28	8	CLPH04008	420
5.0	6.0	28	8	CLPH05008	420
6.0	6.0	28	8	CLPH06008	420

前方锁固式锯片柄 (轴) - 前置螺帽为右牙

MILLING SPINDLES of LSTING AWFS with right tapping (right hand thread)

SAFR



轴径 d	轴径长 L1	柄径 D	订购编号 Order n	建议售价 Price ¥
5	5.2	5	SAFR05005	290
5	5.2	7	SAFR05007	330
6	7.5	7	SAFR06007	330
12.7	11.2	10	SAFR12710	440

钨钢雕刻剖半圆棒 - 短刃型

CARBIDE ENGRAVING BANKS RECISION ROUND-Short life

CLEBS



刃径 d	刃长 L1	全长 L	柄径 D	订购编号 Order n	建议售价 Price ¥
2.0	3.0	40	2	CLEBS0200	70
2.5	4.0	40	2.5	CLEBS0250	70
3.0	5.0	40	3	CLEBS0300	70
3.5	6.0	50	3.5	CLEBS0350	90
4.0	6.0	50	4	CLEBS0400	90
4.5	8.0	50	4.5	CLEBS0450	90
5.0	8.0	50	5	CLEBS0500	90
6.0	9.0	50	6	CLEBS0600	110
7.0	10.0	50	7	CLEBS0700	150
8.0	12.0	60	8	CLEBS0800	150
10.0	15.0	75	10	CLEBS1000	220
12.0	18.0	75	12	CLEBS1200	320

钨钢雕刻剖半圆棒 - 长刃型

CARBIDE ENGRAVING BANKS RECISION ROUND-Long life

CLEBL



刃径 d	刃长 L1	全长 L	柄径 D	订购编号 Order n	建议售价 Price ¥
2.0	6.0	40	2	CLEBL0200	70
3.0	9.0	40	3	CLEBL0300	70
4.0	12.0	50	4	CLEBL0400	100
5.0	15.0	50	5	CLEBL0500	100
6.0	18.0	50	6	CLEBL0600	120
7.0	21.0	50	7	CLEBL0700	160
8.0	24.0	60	8	CLEBL0800	160
10.0	30.0	75	10	CLEBL1000	240
12.0	36.0	75	12	CLEBL1200	340

钨钢扁型定位钻 - 右刃 - 2刃

CARBIDE FLAT POINT END-Right hand cutting-2F

CLPR



刃径 d	尖端夹角 °	全长 L	柄径 D	订购编号 Order n	建议售价 Price ¥
3	60°	50	3	CLPR03060	90
4	60°	50	4	CLPR04060	90
5	60°	50	5	CLPR05060	100
6	60°	50	6	CLPR06060	100
3	90°	50	3	CLPR03090	90
4	90°	50	4	CLPR04090	90
5	90°	50	5	CLPR05090	100
6	90°	50	6	CLPR06090	100
3	120°	50	3	CLPR030C0	90
4	120°	50	4	CLPR040C0	90
5	120°	50	5	CLPR050C0	100
6	120°	50	6	CLPR060C0	100

钨钢扁型定位钻 - 左刃 - 2刃

CARBIDE FLAT POINT END-Left hand cutting-2F

CLPL



刃径 d	尖端夹角 °	全长 L	柄径 D	订购编号 Order n	建议售价 Price ¥
6	60°	25	6	CLPL06060	90
6	80°	25	6	CLPL06080	90
6	90°	25	6	CLPL06090	90
6	100°	25	6	CLPL060A0	90
6	120°	25	6	CLPL060C0	90

钨钢T型刀 - 直刃

CARBIDE T-SLOT CUTTERS-F flute

CLFS



刃径 d	刃长 L1	全长 L	柄径 D	刃数 F	订购编号 Order n	建议售价 Price ¥
15	1.0	50	7	16	CLFS1500100716	590
15	1.5	50	7	16	CLFS1500150716	590
15	2.0	50	7	16	CLFS1500200716	590
15	2.5	50	7	16	CLFS1500250716	640
15	3.0	50	7	16	CLFS1500300716	640
20	1.0	50	7/10	16	CLFS2000100716	650
20	1.5	50	7/10	16	CLFS2000150716	650
20	2.0	50	7/10	16	CLFS2000200716	650
20	2.5	50	7/10	16	CLFS2000250716	700
20	3.0	50	7/10	16	CLFS2000300716	700
25	1.0	50	7/10	16	CLFS2500100716	700
25	1.5	50	7/10	16	CLFS2500150716	700
25	2.0	50	7/10	16	CLFS2500200716	760
25	3.0	50	7/10	16	CLFS2500300716	760
30	1.0	50	7/10	16	CLFS3000100716	780
30	1.5	50	7/10	16	CLFS3000150716	780
30	2.0	50	7/10	16	CLFS3000200716	780
30	2.5	50	7/10	16	CLFS3000250716	820
30	3.0	50	7/10	16	CLFS3000300716	820

钨钢外圆槽铣刀

MICRO BANK CARBIDE CONVEX CUTTERS

AEC

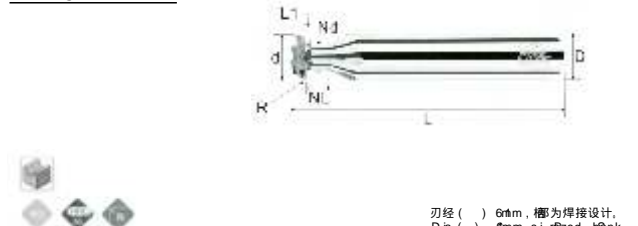

刃径 d	R角 R	刃长 L1	头径 Nd	头长 NL	全长 L	柄径 D	刃数 F	白刃订购编号 Uncoated Order n	建议售价 Price ¥
16.0	0.3R	0.6	8.0	10.0	100	12	10	AEC160006010	923
16.0	0.5R	1.0	8.0	10.0	100	12	10	AEC160010010	923
16.0	1.0R	2.0	8.0	10.0	100	12	10	AEC160020010	923
16.0	1.5R	3.0	8.0	10.0	100	12	10	AEC160030010	923
16.0	2.0R	4.0	8.0	10.0	100	12	10	AEC160040010	1026
16.0	3.0R	6.0	8.0	10.0	100	12	10	AEC160060010	1077
20.0	0.3R	0.6	10.0	14.0	100	12	12	AEC200006012	974
20.0	0.5R	1.0	10.0	14.0	100	12	12	AEC200010012	974
20.0	1.0R	2.0	10.0	14.0	100	12	12	AEC200020012	974
20.0	1.5R	3.0	10.0	14.0	100	12	12	AEC200030012	1064
20.0	2.0R	4.0	10.0	14.0	100	12	12	AEC200040012	1128
20.0	3.0R	6.0	12.0	14.0	100	12	12	AEC200060012	1128
25.0	0.5R	1.0	12.0	16.0	100	16	16	AEC250010016	1064
25.0	1.0R	2.0	12.0	16.0	100	16	16	AEC250020016	1064
25.0	1.5R	3.0	12.0	16.0	100	16	16	AEC250030016	1149
25.0	2.0R	4.0	12.0	16.0	100	16	16	AEC250040016	1179
25.0	3.0R	6.0	12.0	16.0	100	16	16	AEC250060016	1231
30.0	0.5R	1.0	15.0	18.0	100	16	16	AEC300010016	1179
30.0	1.0R	2.0	15.0	18.0	100	16	16	AEC300020016	1179
30.0	1.5R	3.0	15.0	18.0	100	16	16	AEC300030016	1231
30.0	2.0R	4.0	15.0	18.0	100	16	16	AEC300040016	1282
30.0	3.0R	6.0	15.0	18.0	100	16	16	AEC300060016	1359

铣刀 锯片 成型刀

钨钢铣刀

非标成型刀

高速钢铣刀

焊刃式铣刀

钨钢圆棒

# 高速钢铣刀 | High Speed Steel End Milling

## 超钴钢粗皮铣刀

STK

## 超钴钢标准平底铣刀

NACHI

STK

M ZG

## 高速钢锥度铣刀

材质 HSS-C 适合加工钢材, 不锈钢, 铝材及槽加工

尺寸					单价 (人民币)	
刃径	刃长	柄径	全长	加长型	STK	M ZG
6	13	6	57		115	
8	19	10	69		125	
10	22	10	72	45°95	133	165
12	30	12	80	53°110	148	200
14	35	12	90	53°110	166	235
16	40	16	95	63°123	196	270
18	40	16	105	63°123	210	300
20	45	20	110	75°141	232	315
22	45	20	104		300	
25	50	25	120	90°166	365	495
28	55	25	121		510	
30	55	25	125	90°166	560	730
32	60	32	133	106°188	650	870

## 超钴钢球头铣刀

NACHI

STK

M ZG

材质 HSS-C 适合加工钢材, 不锈钢, 铝材及槽加工

尺寸				单价 (人民币)		
刃径	刃长	柄径	全长	6.2-30S	S	K M ZG
R0.75	3	6	55	139	97.0	97.0
R1	4	6	55	139	95.0	95.0
R1.25	5	6	60	139	92.0	92.0
R1.5	6	6	60	139	86.5	86.5
R2	8	6	70	139	86.5	86.5
R2.5	10	6	80	139	86.5	86.5
R3	12	6	90	139	86.5	86.5
R3.5	14	6	90	162	98.0	98.0
R4	16	8	100	162	91.0	91.0
R4.5	18	8	100	194	102	102
R5	20	10	100	194	94.5	94.5
R5.5	22	10	100	233	135	135
R6	24	12	110	233	125	125
R6.5	26	12	110	288		
R7	28	12	110	288	190	190
R7.5	30	12	110	356		
R8	32	16	140	356	190	190
R10	40	20	160	496	253	253
R12.5	50	25	180	623	386	386
R15	60	25	180	892		
R16	60	32	200	1174		
R20	65	32	200	1583		

## 英制超钴钢铣刀

NACHI

STK

M ZG

材质 HSS-C 适合加工钢材, 不锈钢, 铝材及槽加工

尺寸				单价 (人民币)		
刃径	刃长	柄径	全长	S	K	M ZG
1/16	3/16	1/4	2-1/8	46.5		
5/64	7/32	1/4	2-1/4	46.5		
3/32	13/32	1/4	2-1/4	46.5		
1/8	1/2	1/4	2-7/16	38.6		
5/32	9/16	1/4	2-1/2	38.6		
3/16	5/8	1/4	2-1/2	38.6		
1/4	3/4	1/4	2-1/2	38.6		
5/16	3/4	3/8	2-1/2	47.5		
3/8	3/4	3/8	2-1/2	47.5		
1/2	1-1/4	1/2	3-1/4	68.0		
5/8	1-5/8	5/8	3-3/4	104		
3/4	1-5/8	3/4	3-7/8	134		
1"	1-7/8	3/4	4-1/8	228		
1"	2"	1"	4-1/2	248		
1 1/4"	2"	1 1/4"	4-1/2	470		

### 超钴钢加长型 / 特大型平底铣刀

刃径	刃长	柄径	全长	55
1/8	3/4	1/4	2-3/4	55
3/16	7/8	1/4	2-3/4	55
1/4	1-1/4	1/4	3-1/8	55
5/16	1-3/8	3/8	3-1/8	62.5
3/8	1-1/2	3/8	3-1/4	62.5
1/2	2"	1/2	4"	95.5
5/8	2-1/2	5/8	4-5/8	151
3/4	3"	3/4	5-1/4	188
1"	4"	3/4	6-1/4	314
1"	4"	1"	6-1/2	314
1-1/4"	4"	1-1/4"	6-1/2	605

## 超钴钢粗皮铣刀

NACHI

STK

M ZG

材质 HSS-C 适合加工钢材, 不锈钢, 铝材及槽加工

尺寸				单价 (人民币)		
刃径	刃长	柄径	全长	S	K	M ZG
1/4	5/8	3/8	2-7/16	98		
5/16	3/4	3/8	2-1/2	98		
3/8	3/4	3/8	2-1/2	98		
1/2	1-1/4	1/2	3-1/4	135		
5/8	1-5/8	5/8	3-3/4	160		
3/4	1-5/8	3/4	3-3/4	198		
1"	2"	3/4	4"	285		
1"	2"	1"	4"	285		
1 1/4"	2"	1-1/4"	4 1/2	490		

材质 HSS-C 适合加工钢材, 不锈钢, 铝材及槽加工

尺寸					单价 (人民币)						
刃径	刃长	柄径	全长	加长型	6.2-30S	6.2-140S	STK	M ZG			
1	2	6	50		102						
1.5	3	6	50		100		47.8	47.8			
2	7	6	50		95		43.6	43.6			
2.5	7	6	50		95	95	41.6	41.6			
3	9	6	50		85	85	38.6	38.6			
3.5	12	8	60		85	85	40.0	40.0			
4	12	8	60		85	85	38.6	38.6			
4.5	15	8	60		85	85	40	40			
5	15	8	60		85	85	38.6	38.6			
5.5	15	8	60		85	85	40.0	40.0			
6	15	8	60		85	85	38.6	38.6			
6.5	20	10	65		93	93	49.5	49.5			
7	20	10	65		93	93	48.5	48.5			
7.5	20	10	65		93	93	49.5	49.5			
8	20	10	65		93	93	48.5	48.5			
8.5	25	10	75		108	108	51.9	51.9			
9	25	10	75		108	108	50.9	50.9			
9.5	25	10	75		108	108	51.9	51.9			
10	25	10	75		108	108	50.9	50.9			
11	30	12	80		136	136	78.0	78.0			
12	30	12	80		136	136	73.5	73.5			
13	35	16	90		165	165	113	113			
14	35	16	90		165	165	113	113			
15	40	16	95		183	183	118	118			
16	40	16	95		196	196	118	118			
17	40	20	105		220	220	155	155			
18	40	20	105		220	220	155	155			
19	45	20	110		256	256	158	158			
20	45	20	110		256	256	158	158			
21	45	20	110		322	322	209	209			
22	45	20	110		322	322	209	209			
23	50	25	120		363	363	236	236			
24	50	25	120		363	363	236	236			
25	50	25	120		363	363	236	236			
26	50	25	120		406	406	406	406			
27	55	25	125				406	406			
28	55	25	125		483	483	406	406			
29	55	25	125				470	470			
30	55	25	125		578	578	470	470			
31	60	32	145								
32	60	32	145		678	678	525	525			
33	60	32	145		796	796					
34	60	32	145		796	796	703	703			
35	60	32	145		796	796	764	764			
36	60	32	145		880	880	818	818			
37	65	32	150		948	948					
38	65	32	150		948	948	879	879			
39	65	32	150		1100	1100					
40	65	32	150		1100	1100					
42	65	32	150		1224	1224	923	923			
42	65	42	155		1224	1224					
45	70	32	155		1513	1513					
45	70	42	160		1513	1513	1386	1386			
48	70	32	155		1624	1624					
48	70	42	160		1624	1624					
50	70	32	155		1823	1823					
50	70	42	160		1823	1823	1780	1780			

### 超钴钢加长型 / 特大型平底铣刀

刃径	刃长	柄径	全长	6.2-30S / 6.2	STK	M ZG
3	15	6	60	96	53.5	
4	20	6	65	96	53.5	
5	25	6	70	96	53.5	
6	25	6	70	96	53.5	
8	35	8	85	111	60.5	
10	45	10	100	124	73.0	
12	55	12	115	147	105.5	
14	55	16	120	179	159	
16	65/100	16	130/160	220/*	159/228	
18	65	16	130	261	200	
20	75/100/150	20	145/180/230	307/*/*	212/330/400	
22	75	20	145	361	284	
25	90/150	25	165/250	438/*	345/610	
32	95/150/200	32	180/250/280	826/*/*	602/1020/1230	

材质 HSS-C 适合加工钢材, 不锈钢, 铝材及槽加工

锥度	尺寸				单价 (人民币)
	刃径	刃长	柄径	全长	
1/2°	1	4	6	45	102
	1.5	5	6	45	102
	2	6	6	45	102
	2.5	8	6	45	102
	3	10	6	45	102
	4	15	6	50	102
	5	20	6	55	102
	6	20	6	55	117
	8	25	8	65	145
	10	35	10	85	170
	12	55	12	110	230
	12	55	12	110	230
1°	1	4	6	45	102
	1.5	5	6	45	102
	2	6	6	45	102
	2.5	8	6	45	102
	3	10	6	45	102
	4	15	6	50	102
	5	20	6	55	102
	6	20	6	55	117

### SW E2 螺旋焊刃式超微粒钨钢铣刀 - 2 刃过中心 (标准型)

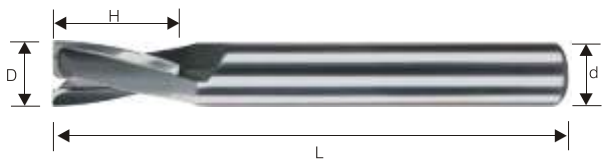

规格型号 Type	尺寸 $\phi_e$ (mm)					订购 编码 Order Number	单价 Price
	外径 $D_{-0.03}^0$	刃长 H	柄长 $d(h7)$	全长 L	齿数 T		
SW E2-12x30H	12	30	12	80	2	361100	205
14x35H	14	35	16	90	2	361102	240
16x40H	16	40	16	95	2	361104	265
18x40H	18	40	20	100	2	361106	315
20x45H	20	45	20	110	2	361108	350
25x50H	25	50	25	120	2	361110	435

### SW EL2 螺旋焊刃式超微粒钨钢铣刀 - 2 刃过中心 (加长型)

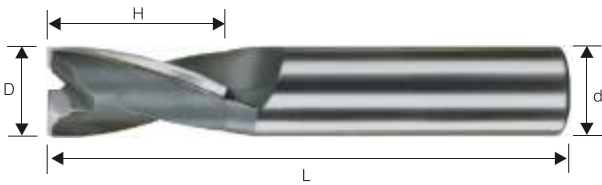

规格型号 Type	尺寸 $\phi_e$ (mm)					订购 编码 Order Number	单价 Price
	外径 $D_{-0.03}^0$	刃长 H	柄长 $d(h7)$	全长 L	齿数 T		
SW EL2-12x40H	12	40	12	90	2	361200	255
14x45H	14	45	12	115	2	361202	290
16x50H	16	50	16	120	2	361204	325
18x60H	18	60	20	120	2	361206	430
20x75H	20	75	20	150	2	361208	520
25x100H	25	100	25	180	2	361210	775

### SW E4 螺旋焊刃式超微粒钨钢铣刀 - 4 刃(标准型)



规格型号 Type	尺寸 $\phi_e$ (mm)					订购 编码 Order Number	单价 Price
	外径 $D_{+0.03}^0$	刃长 H	柄长 $d(h7)$	全长 L	齿数 T		
SW E4-12x30H	12	30	12	80	4	361300	240
14x35H	14	35	16	90	4	361302	280
16x40H	16	40	16	95	4	361304	310
18x40H	18	40	20	100	4	361306	370
20x45H	20	45	20	110	4	361308	410
25x50H	25	50	25	120	4	361310	510
30x55H	30	55	25	125	4	361312	670
32x60H	32	60	32	145	4	361314	765
35x65H	35	65	32	150	4	361316	850
40x65H	40	65	32	150	4	361318	885
45x70H	45	70	32	160	4	361320	1150
50x70H	50	70	32	160	4	361322	1220

### SW EL4 螺旋焊刃式超微粒钨钢铣刀 - 4 刃(加长型)

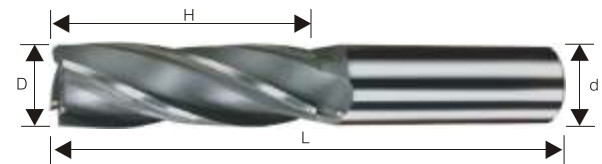

规格型号 Type	尺寸 $\phi_e$ (mm)					订购 编码 Order Number	单价 Price
	外径 $D_{+0.03}^0$	刃长 H	柄长 $d(h7)$	全长 L	齿数 T		
SW EL4-12x40H	12	40	12	90	4	361400	300
14x45H	14	45	16	105	4	361402	340
16x50H	16	50	16	120	4	361404	380
18x60H	18	60	20	120	4	361406	510
20x75H	20	75	20	135	4	361408	615
25x85H	25	85	25	175	4	361410	805
30x100H	30	100	25	195	4	361412	1090
32x105H	32	105	32	205	4	361414	1240
35x105H	35	105	32	205	4	361416	1285
40x105H	40	105	32	205	4	361418	1330
45x105H	45	105	32	205	4	361420	1625
50x125H	50	125	32	240	4	361422	1995

### SW ELL4 螺旋焊刃式超微粒钨钢铣刀 - 4 刃(特长型)

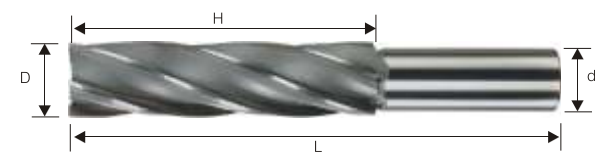

规格型号 Type	尺寸 $\phi_e$ (mm)					订购 编码 Order Number	单价 Price
	外径 $D_{+0.03}^0$	刃长 H	柄长 $d(h7)$	全长 L	齿数 T		
SW ELL4-20x100H	20	100	20	180	4	361500	805
25x120H	25	120	25	210	4	361502	1090
30x120H	30	120	25	210	4	361504	1335
32x120H	32	120	32	210	4	361506	1375
35x150H	35	150	32	250	4	361508	1740
40x150H	40	150	32	250	4	361510	1790
40x200H	40	200	32	305	4	361512	2315
45x150H	45	150	32	250	4	361514	2195
45x200H	45	200	32	305	4	361516	2840
50x150H	50	150	32	250	4	361518	2285
50x200H	50	200	32	305	4	361520	2950

### SW ER4 螺旋焊刃式超微粒钨钢粗铣刀

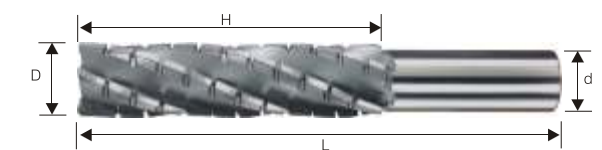

规格型号 Type	尺寸 $\phi_e$ (mm)					订购 编码 Order Number	单价 Price
	外径 $D_{+0.05}^0$	刃长 H	柄长 $d(h7)$	全长 L	齿数 T		
SW ER4-30x60H	30	60	32	140	4	361600	915
30x80H	30	80	32	160	4	361602	1160
30x105H	30	105	32	205	4	361604	1505
32x60H	32	60	32	140	4	361606	950
32x80H	32	80	32	160	4	361608	1195
32x105H	32	105	32	205	4	361610	1540
35x60H	35	60	32	140	4	361612	985
35x80H	35	80	32	160	4	361614	1240
35x105H	35	105	32	205	4	361616	1605
40x60H	40	60	32	140	4	361618	1030
40x80H	40	80	32	160	4	361620	1285
40x105H	40	105	32	205	4	361622	1660
50x105H	50	105	42	205	5	361624	2480
50x125H	50	125	42	225	5	361626	2875
50x150H	50	150	42	250	5	361628	3365
50x205H	50	205	42	305	5	361630	4445

铣刀  
锯片  
成型刀

钨  
钢  
铣  
刀

非  
标  
成  
型  
刀

高  
速  
钢  
铣  
刀

焊  
刃  
式  
铣  
刀

钨  
钢  
圆  
棒

# 焊接式刀具 | Welding Tools

## SW RT

螺旋焊刃式超微粒钨钢筒状粗铣刀



规格型号 Type	尺寸 $\phi$ (mm)					订购 编码 Order Number	单价 Price
	外径 $D_{+0.05}^{+0}$	孔径 d(h7)	刃高 H	全长 L	齿数 T		
SWRT- 60x55H	60	1"	55	70	6	362100	1785
60x80H	60	1"	80	95	6	362102	2505
75x70H	75	1" 1/4	70	85	8	362104	2390
75x80H	75	1" 1/4	80	95	8	362106	3365
75x100H	75	1" 1/4	100	115	8	362108	4145

## SW T 螺旋焊刃式超微粒钨钢筒状铣刀 (加长型)



规格型号 Type	尺寸 $\phi$ (mm)					订购 编码 Order Number	单价 Price
	外径 $D_{+0.05}^{+0}$	孔径 d(h7)	刃高 H	全长 L	齿数 T		
SWT- 60x48H	60	1"	48	65	6	362200	1275
60x70H	60	1"	70	85	6	362202	1775
75x48H	75	1" 1/4	48	65	8	362204	1705
75x70H	75	1" 1/4	70	85	8	362206	2375
75x100H	75	1" 1/4	100	115	8	362208	3315

## SW FT 焊刃式超微粒钨钢筒状平面铣刀

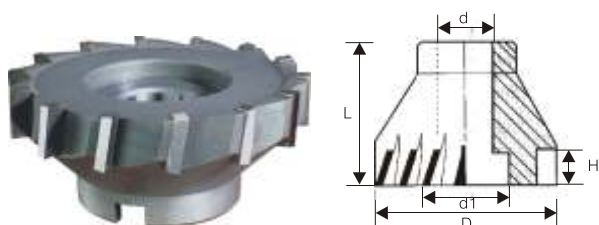

规格型号 Type	尺寸 $\phi$ (mm)						订购 编码 Order Number	单价 Price
	外径 $D_{+1.0}^{+0}$	孔径 d(h7)	刃高 H	底盘 直径 d <sub>1</sub>	全长 L	齿数 T		
SWFT- 75x15H	75	1"	15	46	55	8	362300	690
100x15H	100	1" 1/4	15	60	55	10	362302	1045
125x15H	125	1" 1/4	15	70	55	14	362304	1485
150x15H	150	2"	15	80	55	16	362306	1905

## SW CR

焊刃式超微粒钨钢外角R铣刀



规格型号 Type	尺寸 $\phi$ (mm)						订购 编码 Order Number	单价 Price
	外径 $D_{-0.03}^{+0}$	小径 d1	R角	柄径 d(h7)	全长 L	齿数 T		
SWCR- 18-3.0R	18	10	3.0R	16	100	4	362400	235
20-3.5R	20	11	3.5R	16	100	4	362402	260
22-4.0R	22	12	4.0R	20	100	4	362404	280
24-4.5R	24	12	4.5R	20	120	4	362406	340
25-5.0R	25	13	5.0R	25	120	4	362408	340
28-6.0R	28	14	6.0R	25	120	4	362410	390
31-7.0R	31	15	7.0R	25	120	4	362412	435
33-8.0R	33	15	8.0R	32	130	4	362414	495
37-9.0R	37	17	9.0R	32	130	4	362416	575
42-10.0R	42	20	10.0R	32	130	4	362418	645
44-11.0R	44	20	11.0R	32	130	4	362420	710
48-12.0R	48	22	12.0R	32	150	4	362422	815
50-13.0R	50	22	13.0R	32	150	4	362424	890
52-14.0R	52	22	14.0R	42	150	4	362426	925
54-15.0R	54	22	15.0R	42	150	4	362428	1010
56-16.0R	56	22	16.0R	42	170	4	362430	1115
60-18.0R	60	22	18.0R	42	170	4	362432	1245
64-20.0R	64	22	20.0R	42	170	4	362434	1385

## SW A

焊刃式超微粒钨钢斜度铣刀

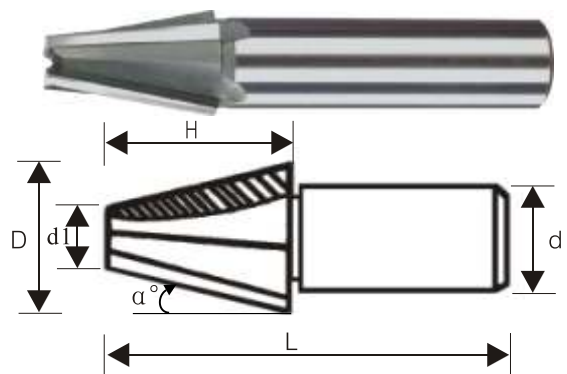

规格型号 Type	尺寸 $\phi$ (mm)						订购 编码 Order Number	单价 Price
	小外径 $D_{+0.1}^{+0}$	刃高 H	单边 角度 $\alpha$	大外径 D	柄径 d(h7)	全长 L		
SWA 6-5°	6	30	5°	11.25	10	70	362500	185
6-8°	6	30	8°	14.53	12	70	362502	200
6-10°	6	30	12°	18.75	16	70	362504	240
6-15°	6	30	15°	26.76	16	85	362506	320
8-5°	8	35	5°	14.12	12	85	362508	390
8-8°	8	35	8°	20.34	16	85	362510	565
8-10°	8	35	10°	27	16	90	362512	485
8-12°	8	35	12°	27	16	90	362514	595
8-15°	8	35	15°	27	16	90	362516	695
10-5°	10	40	5°	14.12	12	85	362518	320
10-8°	10	40	8°	21.24	16	90	362520	485
10-10°	10	40	10°	27	16	90	362522	595
10-12°	10	40	12°	27	16	90	362524	695
10-15°	10	40	15°	27	16	90	362526	795

铣刀  
锯片  
成型刀

钨  
钢  
铣  
刀

非  
标  
成  
型  
刀

高  
速  
钢  
铣  
刀

焊  
刃  
式  
铣  
刀

钨  
钢  
圆  
棒



### SW A 54° 焊刃式超微粒钨钢倒角铣刀

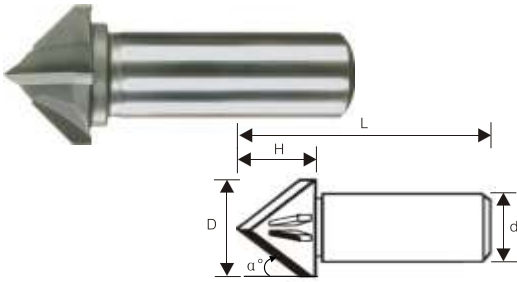

规格型号 Type	尺寸 $\phi$ (mm)						订购 编码 Order Number	单价 Price
	外径 $D_{+0.05}^{+0}$	刃高 H	单边 角度°	柄径 d(h7)	全长 L	齿数 T		
SWA45°-20	20	10	45°	16	90	2	363100	205
-25	25	12	45°	16	90	2	363102	255
-30	30	15	45°	20	100	2	363104	340
-35	35	17	45°	20	100	2	363106	390
-40	40	20	45°	25	100	2	363108	460
-50	50	25	45°	32	110	4	363110	920
-60	60	30	45°	32	120	6	363112	1340

### SW CS 45° 焊刃式超微粒钨钢内孔倒角刀 (1 刀用型)

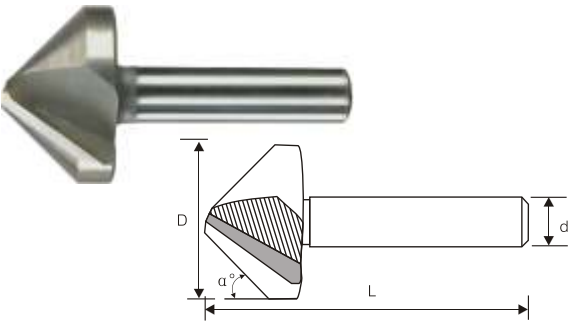

规格型号 Type	尺寸 $\phi$ (mm)					订购 编码 Order Number	单价 Price
	外径 $D_{+0.05}^{+0}$	柄径 d(h7)	全长 L	单边 角度°	齿数 T		
SWCS45° 12X1T	12	8	60	45°	1T	363200	
16X1T	16	10	65	45°	1T	363202	
20X1T	20	10	70	45°	1T	363204	
25X1T	25	10	80	45°	1T	363206	
31X1T	31	12	80	45°	1T	363208	
40X1T	40	12	85	45°	1T	363210	
50X1T	50	12	85	45°	1T	363212	

### SW CS 45° 焊刃式超微粒钨钢内孔倒角刀 (3 刀机用型)

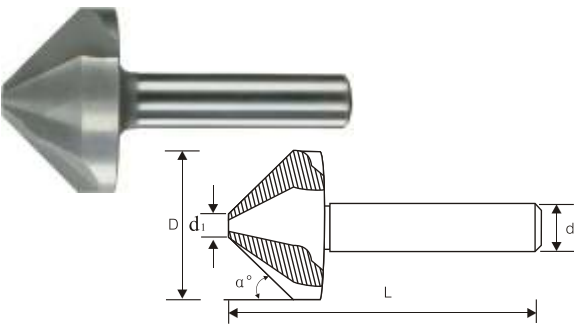

规格型号 Type	尺寸 $\phi$ (mm)						订购 编码 Order Number	单价 Price
	外径 $D_{+0.05}^{+0}$	最小径 $d_1$	柄径 d(h7)	全长 L	单边 角度°	齿数 T		
SWCS45° 12.4x3T	12.4	4.5	8	56	45°	3T	363300	
16.5x3T	16.5	5	10	60	45°	3T	363302	
20.5x3T	20.5	6	10	65	45°	3T	363304	
25x3T	25	6.5	10	65	45°	3T	363306	
31x3T	31	7.5	12	70	45°	3T	363308	
35x3T	35	7.5	12	70	45°	3T	363310	
40x3T	40	8	12	75	45°	3T	363312	
50x3T	50	9	12	80	45°	3T	363314	

### SW T 焊刃式超微粒钨钢 T 型铣刀 (平齿刃)

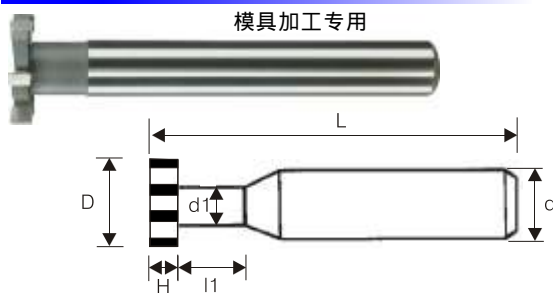

规格型号 Type	尺寸 $\phi$ (mm)							订购 编码 Order Number	单价 Price
	外径 D	刃高 H	颈径 $d_1$	颈长 l	柄径 d(h7)	全长 L	齿数 T		
SWT-16x(3-12)H	16	3/4/5/6/8/10/12	7	15	12	100	4	363400	190
20x(3-12)H	20	3/4/5/6/8/10/12	10	15	12	100	4	363402	190
25x(3-12)H	25	3/4/5/6/8/10/12	13	15	16	120	6	363404	285
30x(3-12)H	30	3/4/5/6/8/10/12	15	15	16	120	6	363406	290
32x(3-12)H	32	3/4/5/6/8/10/12	15	15	16	120	6	363408	290
35x(3-12)H	35	3/4/5/6/8/10/12	15	15	16	120	6	363410	300
40x(3-12)H	40	3/4/5/6/8/10/12	21	15	25	140	6	363412	380
45x(3-12)H	45	3/4/5/6/8/10/12	23	15	25	140	6	363414	380
50x(3-12)H	50	3/4/5/6/8/10/12	24.5	15	25	140	8	363416	530
60x(3-12)H	60	3/4/5/6/8/10/12	30	20	32	140	10	363418	630

### SW TS 焊刃式超微粒钨钢 T 型铣刀 (千鸟刃)

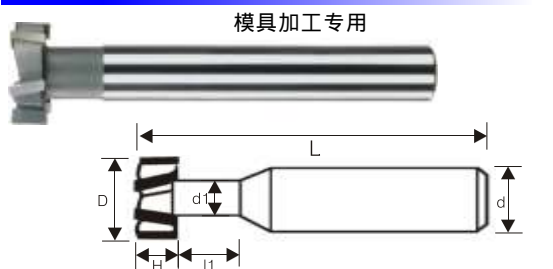

规格型号 Type	尺寸 $\phi$ (mm)							订购 编码 Order Number	单价 Price
	外径 D	刃高 H	颈径 $d_1$	颈长 l	柄径 d(h7)	全长 L	齿数 T		
SWTS-16x(6-12)H	16	6/8/10/12	7	15	12	100	4	363500	235
20x(6-12)H	20	6/8/10/12	10	15	12	100	4	363502	235
25x(6-12)H	25	6/8/10/12	13	15	16	120	6	363504	355
30x(6-12)H	30	6/8/10/12	15	15	16	120	6	363506	360
32x(6-12)H	32	6/8/10/12	15	15	16	120	6	363508	360
35x(6-12)H	35	6/8/10/12	15	15	16	120	6	363510	380
40x(6-12)H	40	6/8/10/12	21	15	25	140	6	363512	470
45x(6-12)H	45	6/8/10/12	23	15	25	140	6	363514	470
50x(6-12)H	50	8/10/12	24.5	15	25	140	8	363516	660
60x(6-12)H	60	8/10/12	30	20	32	140	10	363518	790

# 焊接式刀具 | Welding Tools

## SW T I 焊刀式超微粒钨钢T型铣刀 (平齿刃)

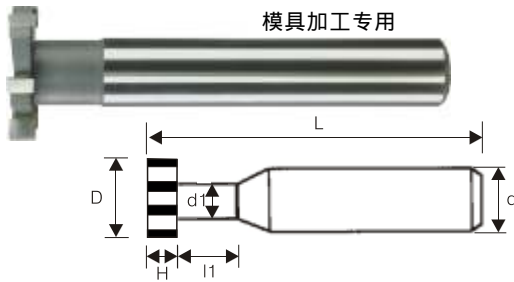

规格型号 Type	尺寸 Size (mm)							订购 编码 Order Number	单价 Price
	外径 D	刃高 H	颈径 d <sub>1</sub>	颈长 l	柄径 d(h7)	全长 L	齿数 T		
SWTI-3/4"x1/8"H	3/4"	1/8"	10	12	1/2"	2"1/4	4	364100	160
3/4"x5/32"H	3/4"	5/32"	10	12	1/2"	2"1/4	4	364102	160
1"x1/8"H	1"	1/8"	13	12	1/2"	2"3/4	5	364104	230
1"x3/16"H	1"	3/16"	13	12	1/2"	2"3/4	6	364106	230
1"x1/4"H	1"	1/4"	13	12	1/2"	2"3/4	6	364108	260
1"1/4x3/16"H	1"1/4	3/16"	15	12	1/2"	2"3/4	6	364110	230
1"1/4x1/4"H	1"1/4	1/4"	15	12	1/2"	2"3/4	6	364112	260
1"1/4x5/16"H	1"1/4	5/16"	15	12	1/2"	2"3/4	6	364114	275

## T型铣刀分差表

外径公差	刃高公差	外径公差	刃高公差	外径公差	刃高公差
~ 10以下 -0.04 -0.13	~ 3以下 0.02 0-08	~ 30以下 -0.06 -0.19	~ 10以下 0-04 0-13	~ 80以下 -0.10 -0.29	~ 30以下 0-06 0-19
~ 18以下 -0.05 -0.16	~ 6以下 0-03 0-10	~ 50以下 -0.08 -0.24	~ 18以下 0-05 0-16		

## SW D 54° 焊刀式超微粒钨钢鸠尾槽铣刀 - 45°

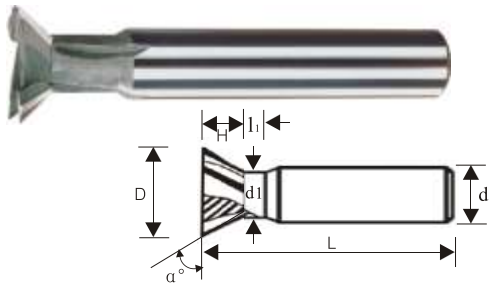

规格型号 Type	尺寸 Size (mm)								订购 编码 Order Number	单价 Price
	外径 D	刃高 H	颈径 d <sub>1</sub>	颈长 l	单边 角度 °	柄径 d(h7)	全长 L	齿数 T		
SWD45°-20	20	6	9	15	45°	12	95	4	364200	230
-25	25	7	10	15	45°	12	95	4	364202	280
-30	30	8	11	15	45°	16	100	4	364204	350
-35	35	10	13	15	45°	16	100	4	364206	425
-40	40	12	13	15	45°	20	100	6	364208	630
-45	45	13	17	15	45°	20	100	6	364210	775
-50	50	15	17	15	45°	25	105	6	364212	910
-60	60	18	21	15	45°	25	110	6	364214	1115
-65	65	20	21	20	45°	25	110	6	364216	1225

## SW D 66° 焊刀式超微粒钨钢鸠尾槽铣刀 - 60°

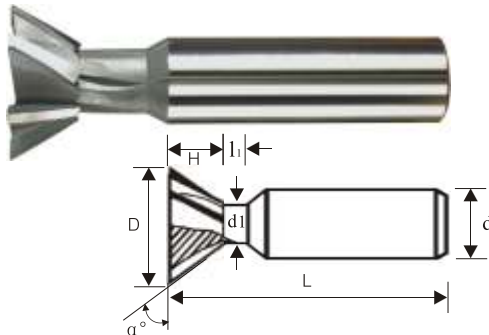

规格型号 Type	尺寸 Size (mm)								订购 编码 Order Number	单价 Price
	外径 D	刃高 H	颈径 d <sub>1</sub>	颈长 l	单边 角度 °	柄径 d(h7)	全长 L	齿数 T		
SWD60°-20	20	8	9	15	60°	12	90	4	364300	240
25	25	11	10	15	60°	12	95	4	364302	300
30	30	14	11	15	60°	20	100	4	364304	400
35	35	15	15	15	60°	20	100	6	364306	590
40	40	17	17	20	60°	20	105	6	364308	665
45	45	20	19	20	60°	20	105	6	364310	865
50	50	22	22	20	60°	25	110	6	364312	1005
55	55	26	22	20	60°	25	110	6	364314	1140
60	60	28	25	20	60°	32	120	6	364316	1270
65	65	32	25	20	60°	32	120	6	364318	1380

## SW DT 08 焊刀式超微粒钨钢鸠尾槽筒状铣刀 - 60°

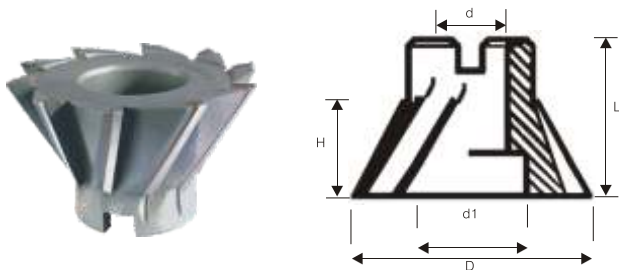

规格型号 Type	尺寸 Size (mm)						订购 编码 Order Number	单价 Price
	外径 D	刃高 H	孔径 d(h7)	底盘 直径 d <sub>1</sub>	总高度 L	齿数 T		
SWDT60°-80	80	30	1"	42	50	8	364400	1410
SWDT60°-100	100	40	1"	50	60	10	364402	2180
SWDT60°-100	100	40	1"1/4	50	60	10	364404	2180
SWDT60°-125	125	50	1"1/4	60	70	10	364406	3030
SWDT60°-150	150	55	1"1/2	80	75	12	364408	4030

## SW ST 焊刀式超微粒钨钢筒状侧铣刀

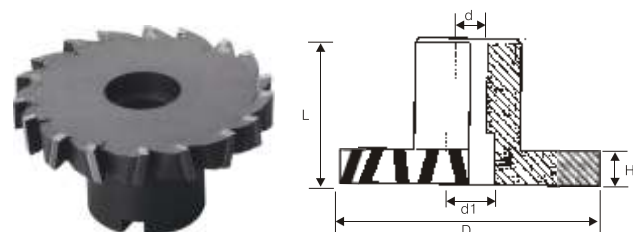

规格型号 Type	尺寸 Size (mm)						订购 编码 Order Number	单价 Price
	外径 D	刃高 H	孔径 d(h7)	底盘 直径 d <sub>1</sub>	总高度 L	齿数 T		
SWST-100x16H	100	16	1"1/4	55	60	14	364500	1295
SWST-125x18H	125	18	1"1/4	60	60	16	364502	1770
SWST-150x20H	150	20	1"1/4	70	60	18	364504	2330

铣刀  
锯片  
成型刀

钨钢  
铣刀

非标  
成型刀

高速  
钢铣刀

焊刀  
式铣刀

钨钢  
圆棒

SWS 焊刃式超微粒钨钢侧铣刀



直刃(25.4孔)

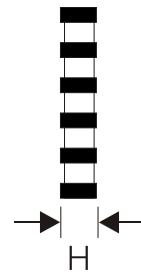
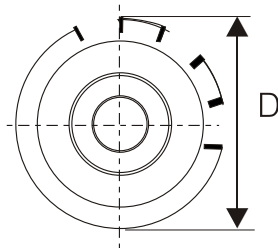

千鳥刃(25.4孔)

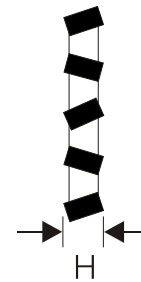
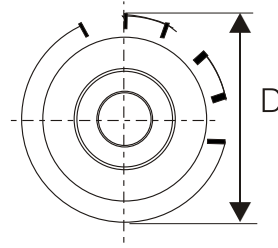

铣刀  
锯片  
成型刀

钨  
钢  
铣  
刀

非  
标  
成  
型  
刀

高  
速  
钢  
铣  
刀

焊  
刃  
式  
铣  
刀

钨  
钢  
圆  
棒

规格型号 Type	尺寸 &e (mm)			订购 编码 Order Number	单价 Price
	外径 D <sup>+0.05</sup> <sub>+0</sub>	刃厚 H <sup>+0.02</sup> <sub>+0</sub>	齿数 T		
SWS-75x3H	75	3	14	365100	380
SWS-75x4H	75	4	14	365102	380
SWS-75x5H	75	5	14	365104	380
SWS-75x6H	75	6	14	365106	380
SWS-75x7H	75	7	14	365108	470
SWS-100x3H	100	3	16	365110	450
SWS-100x4H	100	4	16	365112	450
SWS-100x5H	100	5	16	365114	450
SWS-100x6H	100	6	16	365116	450
SWS-100x7H	100	7	16	365118	560
SWS-125x3H	125	3	18	365120	450
SWS-125x4H	125	4	18	365122	530
SWS-125x5H	125	5	18	365124	530
SWS-125x6H	125	6	18	365126	530
SWS-125x7H	125	7	18	365128	660
SWS-150x3H	150	3	20	365130	625
SWS-150x4H	150	4	20	365132	625
SWS-150x5H	150	5	20	365134	625
SWS-150x6H	150	6	20	365136	625
SWS-150x7H	150	7	20	365138	775
SWS-175x5H	175	5	20	365140	695
SWS-175x6H	175	6	20	365142	695
SWS-175x7H	175	7	20	365144	855
SWS-200x5H	200	5	24	365146	2100
SWS-200x6H	200	6	24	365148	2100
SWS-200x7H	200	7	24	365150	2600

规格型号 Type	尺寸 &e (mm)			订购 编码 Order Number	单价 Price
	外径 D <sup>+0.05</sup> <sub>+0</sub>	刃厚 H <sup>+0.02</sup> <sub>+0</sub>	齿数 T		
SWSS-75x8H	75	8	14	365200	585
SWSS-75x9H	75	9	14	365202	700
SWSS-75x10H	75	10	14	365204	700
SWSS-75x11H	75	11	14	365206	810
SWSS-75x12H	75	12	14	365208	810
SWSS-100x8H	100	8	16	365210	700
SWSS-100x9H	100	9	16	365212	830
SWSS-100x10H	100	10	16	365214	830
SWSS-100x11H	100	11	16	365216	915
SWSS-100x12H	100	12	16	365218	915
SWSS-125x8H	125	8	18	365220	825
SWSS-125x9H	125	9	18	365222	985
SWSS-125x10H	125	10	18	365224	985
SWSS-125x11H	125	11	18	365226	1140
SWSS-125x12H	125	12	18	365228	1140
SWSS-150x8H	150	8	20	365230	970
SWSS-150x9H	150	9	20	365232	1155
SWSS-150x10H	150	10	20	365234	1155
SWSS-150x11H	150	11	20	365236	1340
SWSS-150x12H	150	12	20	365238	1340
SWSS-175x8H	175	8	20	365240	1070
SWSS-175x9H	175	9	20	365242	1275
SWSS-175x10H	175	10	20	365244	1275
SWSS-175x11H	175	11	20	365246	1480
SWSS-175x12H	175	12	20	365248	1480
SWSS-200x8H	200	8	24	365250	1300
SWSS-200x9H	200	9	24	365252	1550
SWSS-200x10H	200	10	24	365254	1550
SWSS-200x11H	200	11	24	365256	1800
SWSS-200x12H	200	12	24	365258	1800

# 焊接式刀具 | Welding Tools

## SW C 焊刃式超微粒钨钢沉头铣刀



规格型号 Type	尺寸 $\phi$ (mm)								订购 编码 Order Number	单价 Price
	外径 D (H7)	刃长 H	沈头径 D <sub>1</sub> (h7)	沈头长 L <sub>1</sub>	颈径 D <sub>2</sub>	工作长 L	齿数 T	莫式锥 MT		
SWC-21x15H-MT	21	15	15.9	15	18	110	4	3	366100	445
SWC-26x15H-MT	26	15	19.9	15	23	110	4	3	366102	535
SWC-31x15H-MT	31	15	24.9	15	27	110	4	3	366104	590
SWC-36x15H-MT	36	15	29.9	15	30	110	4	4	366106	805
SWC-41x15H-MT	41	15	34.9	15	36	110	6	4	366108	955
SWC-46x15H-MT	46	15	39.9	15	39	110	6	4	366110	1045
SWC-51x15H-MT	51	15	44.9	15	46	110	6	4	366112	1160
SWC-56x15H-MT	56	15	49.9	15	48	110	6	4	366114	1260
SWC-61x15H-MT	61	15	54.9	15	50	110	8	4	366116	1380
SWC-66x15H-MT	66	15	59.9	15	56	110	8	4	366118	1510

## SW B 焊刃式超微粒钨钢右斜插铣刀 - 扩孔修正刀

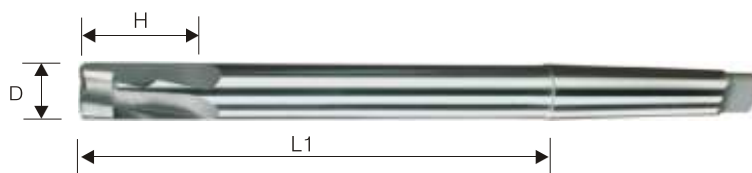

规格型号 Type	尺寸 $\phi$ (mm)					订购 编码 Order Number	单价 Price
	外径 D (H7)	刃长 H	工作长 L	莫式锥柄 MT	齿数 T		
SWB-15.7x11HXMT	15.7	11	150	3#	2	366200	330
SWB-19.7x11HXMT	19.7	11	200	3#	2	366202	430
SWB-24.7x11HXMT	24.7	11	200	3#	4	366204	545
SWB-29.7x11HXMT	29.7	11	230	4#	4	366206	715

## M ZG 高质量钨钢圆棒 (圆刀)



直径	全长	单价 Price (人民币)			直径	全长	单价 Price (人民币)		
		HRC50	HRC55	HRC65			HRC50	HRC55	HRC65
1-2	100	25	37.5		10	100	300	390	750
2	150	75			10	150	490		
2.5-3	100	35	45	125	10	200	690		
3	200	100			11	100	375	475	
4	100	55	75	225	12	100	430	560	1200
4	150	90			12	150	750		
4	200	125			12	200	990		
5	100	80	105		14	100	600		
5	200	190			16	100	775		
6	100	115	160	400	18	100	1000		
6	150	200			20	100	1200		
6	200	275							
7	100	150	200						
8	100	200	250	550					
8	150	340							
8	200	450							
9	100	250	325						

铣刀  
锯片  
成型刀

钨  
钢  
铣  
刀

非  
标  
成  
型  
刀

高  
速  
钢  
铣  
刀

焊  
刃  
式  
铣  
刀

钨  
钢  
圆  
棒